



Operating Parameters: Bit Load for Diamond Impregnated Core Bits

General guidelines for the determination of bit load

The lowest possible bit load or “weight-on-bit” (WOB) that will provide an acceptable rate of penetration should be applied when drilling with diamond impregnated core bits. In particularly deep holes, it is often necessary to “hold back” on the drill string in order to achieve the desired WOB while drilling.

Determining the appropriate bit load is a function of both the matrix type as well as the bit face bearing area, that is, the actual contact area of the bit face with the formation being drilled. The bit face bearing area is largely influenced by the waterway configuration that has been selected for use.

Always verify that the selected bit load does not exceed the load bearing capacity of the drill string in use.

Relationship between matrix type and MAXIMUM recommended bit load

XT-Series Matrix Types	S-Series Matrix Types	HR-Series Matrix Types	D-Series Matrix Types	Maximum Recommended Bit Load per Bit Face Bearing Area	
XT7	S3, S6	-	D2, D4	175 kg/cm ²	2,500 lbs/in ²
XT10	S9	-	D6, D8, D9	155 kg/cm ²	2,200 lbs/in ²
XT13	S11, S12	HR7, HR9, HR14	-	140 kg/cm ²	2,000 lbs/in ²
XT15	-	HR11, HR12	-	125 kg/cm ²	1,800 lbs/in ²

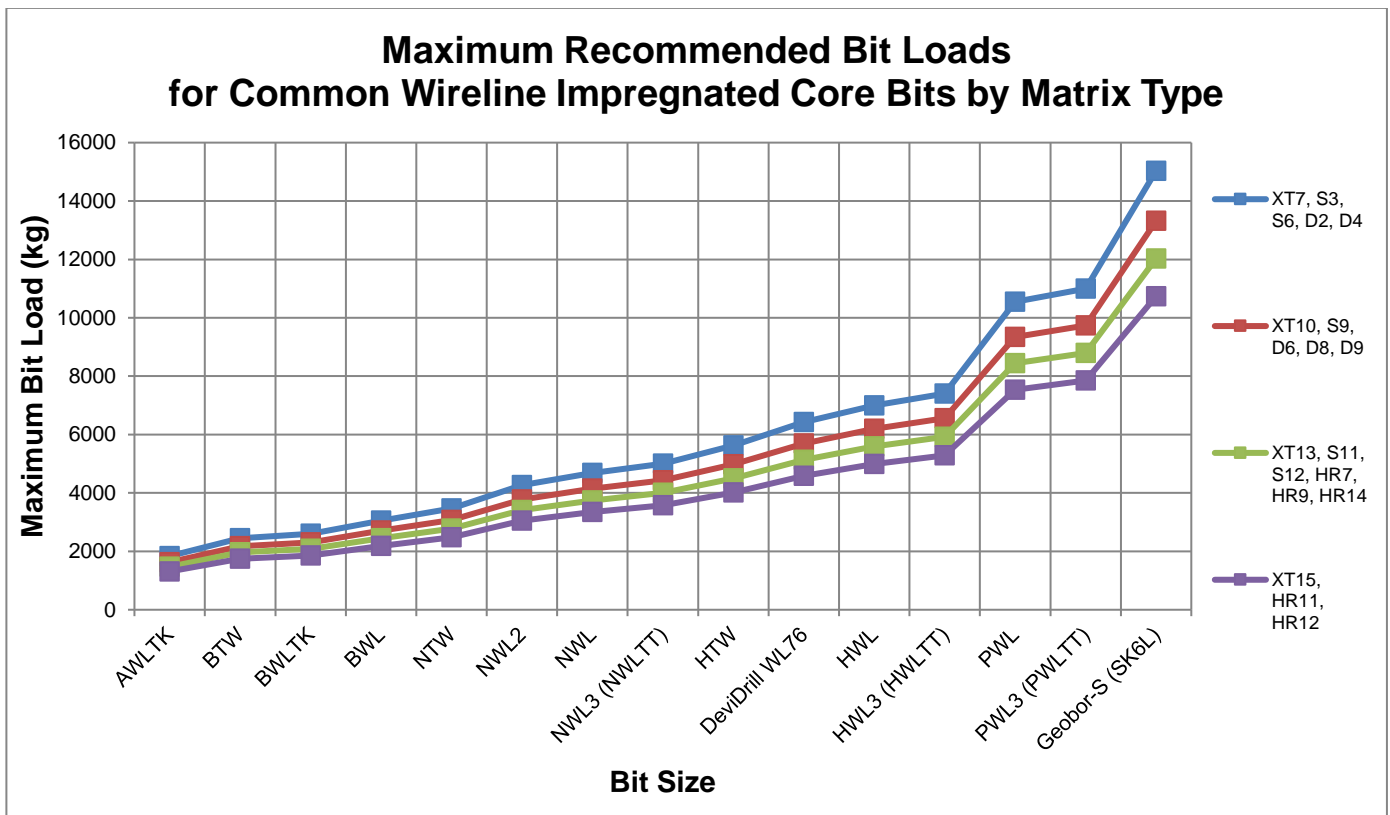

Maximum Recommended Bit Loads for Common T-Series Impregnated Core Bits by Matrix Type

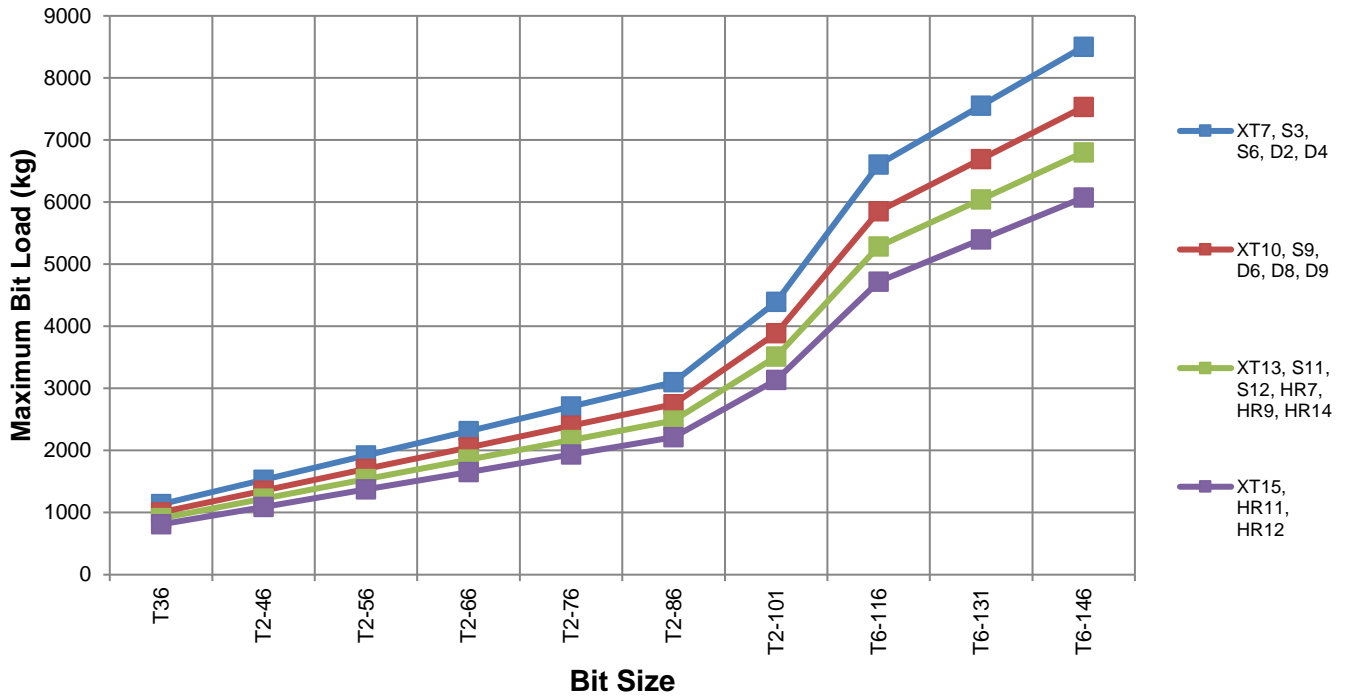

It is important to take the bit's waterway configuration into consideration when determining the appropriate bit load to apply. Multiply the maximum bit load values given in the previous graphs by the values given in the following tables to reduce the maximum applied bit load to an appropriate value based on the waterway configuration in use.

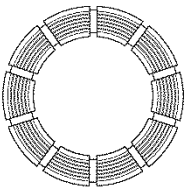
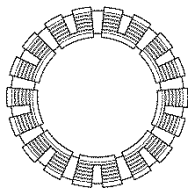
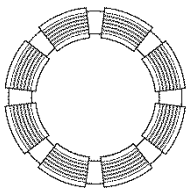
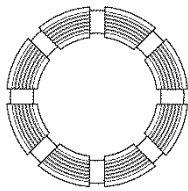
Regular (Style 'W')	T-Turbo (Style 'TT')	Trapezoidal Extra Wide (Style 'TXW')	Extra Extra Wide (Style 'XXW')
			
1.00	0.78	0.92	0.88

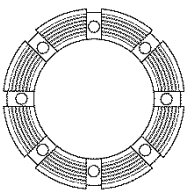
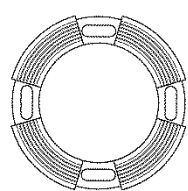
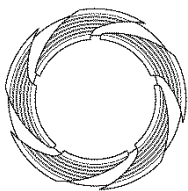
Face Discharge (Style 'FD')	Slot Face Discharge (Style 'SFD')	VORTEX (Style 'VX')
		
0.88	0.78	1.00

MINIMUM recommended bit load

Insufficient bit load will cause the diamonds on the bit face to become blunt as they will be unable to micro-fracture so as to expose new cutting edges. As a result, the bit will not perform effectively due to a diminished rate of penetration.

The minimum recommended bit load per bit face bearing area for all Dimatec impregnated bits is 90 kg/cm² (or 1,280 lbs/inch²).

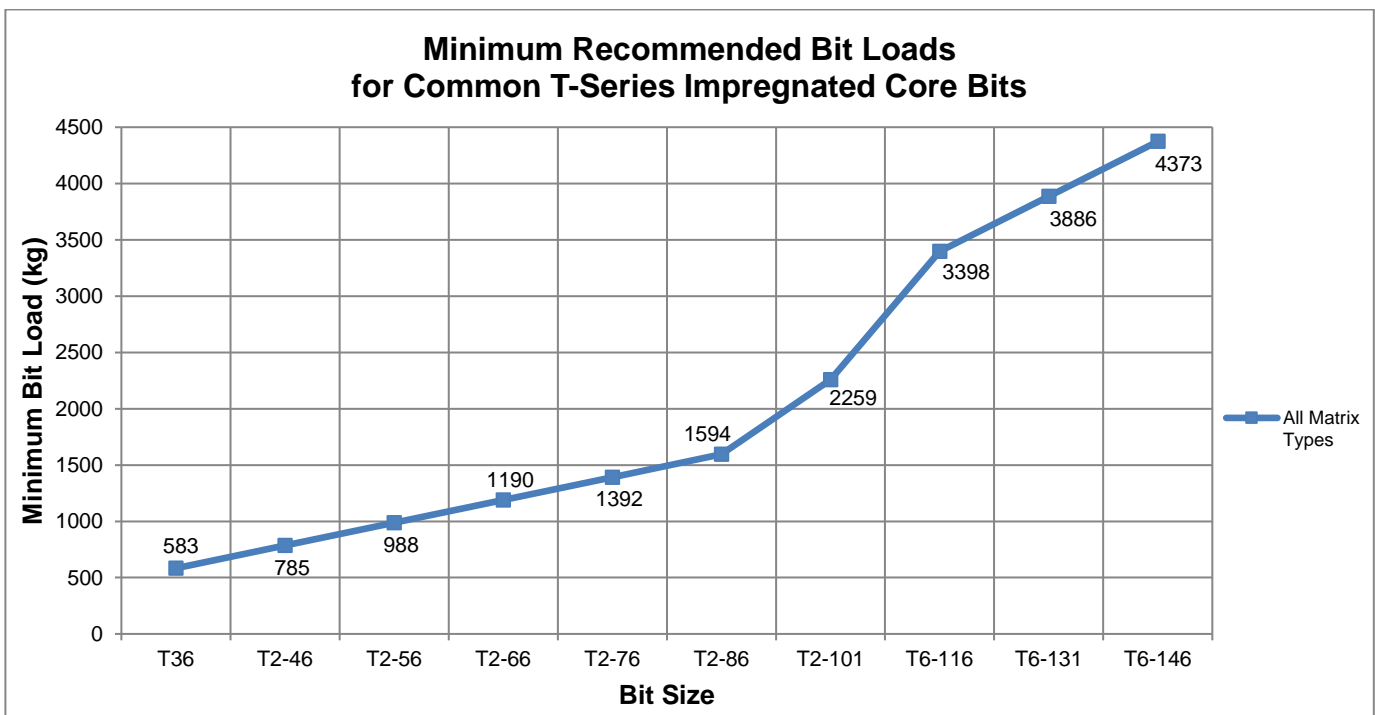
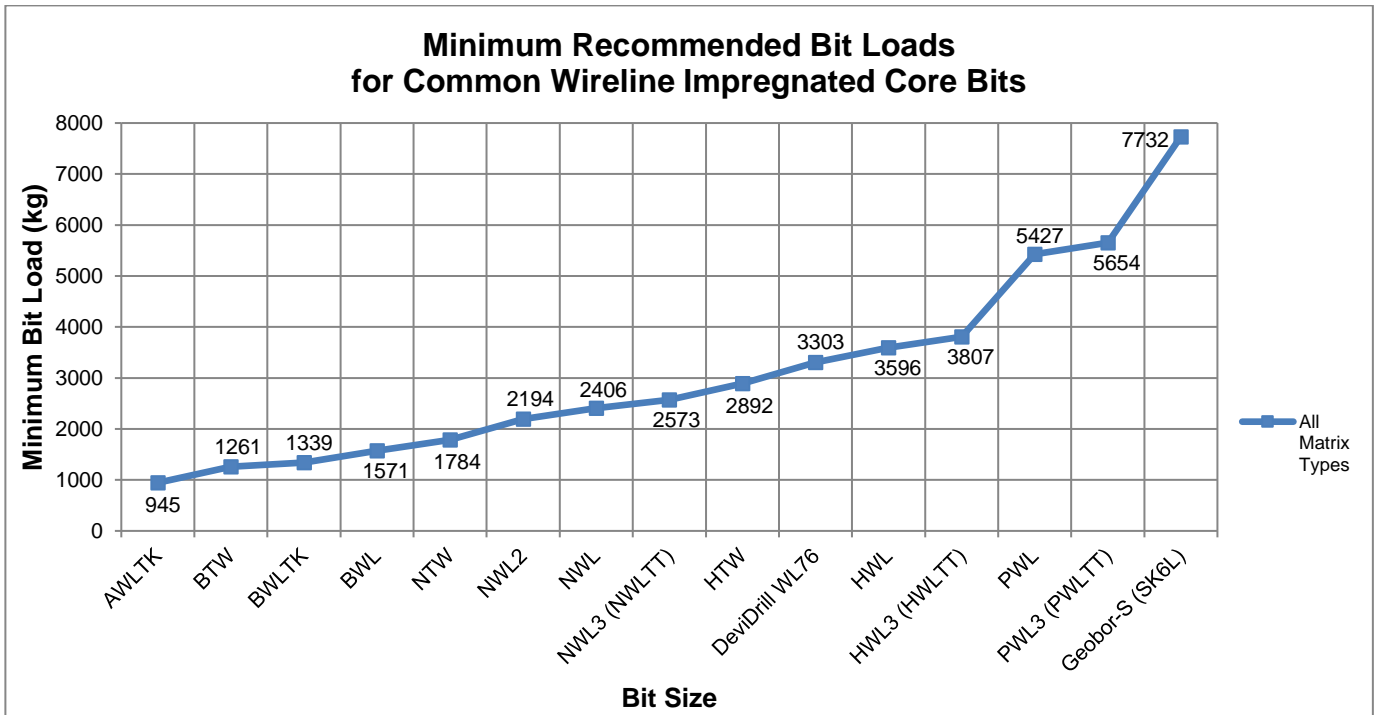

Other considerations pertaining to applied bit load

1. Unnecessarily high bit loads will not only damage the bit but will also cause significant damage to both the drill string as well as the drilling machine itself.
2. Applied bit loads may be reduced by changing to:
 - A softer (higher number designation) **XT-Series**, **S-Series**, **HR-Series** or **D-Series** matrix type and/or
 - A waterway configuration that will reduce the bit's contact area with the formation.

Conversion factors

Length

1 mm = 0.039 inch

1 inch = 25.4 mm

Force

1 N = 0.225 lbf

1 kN = 225 lbf

1 lbf = 4.45 N

Mass

1 kg = 2.205 lb

1 lb = 0.454 kg

Pressure

1 MPa = 1 N/mm²

1 MPa = 145 lb/inch²

1 Bar = 100 kPa = 14.5 lb/inch²

1 lb/inch² = 0.0069 MPa

1 lb/inch² = 6.9 kPa

Volume

1 litre = 0.264 gal (US)

1 litre = 0.220 gal (Imperial)

1 gal (US) = 3.785 litres

1 gal (Imperial) = 4.546 litres

Technical Data Sheet TD109
Revision 7
Document Release Date: August 6, 2019

The technical application data in this document is intended as a basic guideline for the selection of the appropriate tools for your job. As drilling conditions and the capabilities of drilling equipment vary considerably from site to site, it is impossible to define absolute parameters for the application of our drilling tools. Some experimentation on the part of the end user may be required as parameters outside of those recommended in Dimatec's product literature may be applicable. Every effort has been made to ensure the accuracy of the data contained in this document. Dimatec Inc. cannot accept any liability due to errors or omissions in the data that we provide. Dimatec Inc. is constantly working to improve our products and therefore reserve the right to make changes to materials, specifications, prices and technical data without prior notice.

Dimatec Inc. • 180 Cree Crescent • Winnipeg, Manitoba, Canada R3J 3W1
Telephone: Toll-Free 1-866-202-5875 (Canada and US) or (204) 832-2828 • Fax: (204) 832-4268 • E-mail: info@dimatec.com • Website: www.dimatec.com